

SENT-Simulyzer



Hardware version	Up to 2.0
Software version	1.0
Technical data sheet version:	1.5
Order number	1.0300
Created:	(1.0) 04.08.2014
	(1.1) 20.09.2015 correction supply voltage external sensors
	(1.2) 20.12.2016 Pin assignment pin 1 added
	(1.3) 03.08.2017 Block diagram added, wiring updated
	(1.4) 18.11.2018 Pin 1 definition/operating system correction
	(1.5) 10.10.2021 Company information edited

Table of contents:

1. General.....	3
2. Working modes.....	3
2.1 ECU mode	3
2.2 Sensor mode.....	3
2.3 Passive mode	3
3. SENT-Bus parameter	4
4. Measurement data recording.....	4
4.1 FPGA-Version.....	4
4.2 Sample Rates	4
5. Presentation of the measurement data.....	4
5.1 Graphical presentation	4
5.2 Presentation in table form	4
6. Stop of the measurement data recording	5
7. Trigger of the measurement data - trigger events	5
8. Export of the measurement data	5
9. Overview of the measurement data.....	5
10. Connections.....	6
10.1 Interface and digital input/output.....	7
10.2 Block diagram SENT power supply and SENT data	7
10.3 Pin assignment of interface.....	8
10.4 Pin assignment 25-pol. digital/analog I/O -female connector-.....	8
11. Wiring	9
11.1 Wiring ECU mode	9
11.2 Wiring Sensor mode.....	9
11.3 Wiring Passive mode	10
12. Technical data	10
13. Electrical data.....	10
14. Environment conditions	10
15. Software system prerequisites	11
16. More information and tutorials.....	11

1. General

Sensors of automotive technique communicate via SENT-Bus with the control unit. With the *SENT-Simulyzer* data can be read quickly and easy and is able to react to the situation using simulated data.

The *SENT-Simulyzer* is connected via USB cable with a Windows-based software.

2. Working modes

2.1. ECU mode

The *SENT-Simulyzer* supplies the sensor with voltage and generates defined master data. Parallel the data which are sent will be recorded. The data communication between the simulated ECU and the sensor is displayed and recorded.

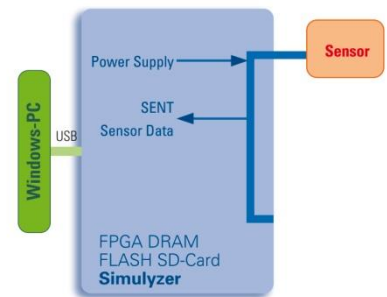

2.2. Sensor mode

The *SENT-Simulyzer* simulates a sensor by generating according data. The data communication between the ECU and the simulated sensor is displayed and recorded.

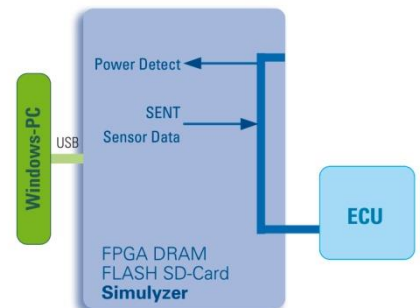

2.3. Passive mode:

The data communication between the sensor and the control unit will be recorded and visualized.

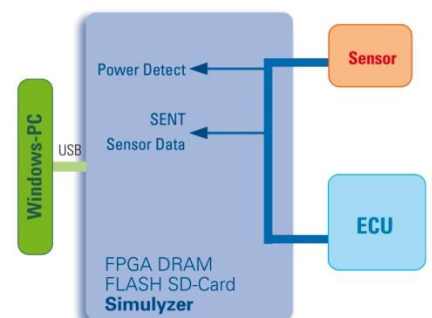

3. SENT-BUS parameter

Data length/ clock rate et all.	According to the SAE SENT specification
Error detection	CRC (Standard New, Standard Legacy, SPC New, SPC Legacy)
Supply voltage of the external sensors (ECU-Mode)	2,5 V to 20 V
High/Low-voltage level of the digital inputs	2V
High/Low-voltage level of the digital outputs	CMOS outputs with $V_{dd}=2,5\text{ V to }6\text{ V}$

4. Measurement recording

The SENT data are recorded as a FPGA decoded data in common with a time stamp.

The resolution is 1 μs . The data are stored in a file up to 4 gigabyte. The file is organized as a ring buffer (first in/last out) During this time, the data are shown as permanently changing numbers or characteristics in the presentation window.

4.1. FPGA versions

The respective FPGA version have to be accorded to the respective software version.
History of the FPGA version:

Software-Version	FPGA-Version	Firmware
1.0	0x0501	0x0109

4.1. Sample-Rates of the AUX inputs

Samplerrates of the Aux analog inputs depending on the number of used analog inputs:

Sample rates	
1 used input	100 k samples/s
2 used inputs	1. Signal with 50 k samples/s 2. Signal with 50 k samples/s
3 used inputs	1. Signal with 50 k samples/s 2. and 3. Signal with 25 k samples/s
4 used inputs	1. Signal with 50 k samples/s 2 , 3. and 4. Signal with 16,67 k samples/s

5. Presentation of the measurement data

5.1. Graphical presentation

The data of the ECU as well as the sensors are presented as an analog-signal and as a digital signal with separate free selctable colors over a time axis. Trigger values and CRC resp. Parity error are marked up. The unit of the vertical axis is LSB, but can be changed in other units corresponding to the physical unit. The time section and the zoom of the presentation can be done individual.

5.2. Presentation in table form

The measurement data are additionally displayed as a textual table. Thereby each row represents a data. At the columns the time stamp, the hexadecimal value of the transmitted data frame of the ECU and the sensors as well as the extraced measurement data value are displayed. If an CRC error occurs the corresponding line will be highlighted in red.

6. Stop of the measurement data recording

After starting the measurement data recording the measurement cycle can be stopped by following variations:

- Manual - by clicking on the stop button of the software
- After a defined time
- After a defined number of cycles.

7. Trigger of the measurement data - trigger events

By defining trigger values, specified events (trigger events) can be recorded and saved.

Definition of trigger values:

- Recognize a CRC error
- Data value levels: go below or beyond of a data value
- External trigger voltage:
Recognition of a voltage at the trigger input (min. 2 V- max. 5 V)

After trigger a free defined number of data will be recorded. The according trigger events can be stored in defined time sections. By triggering a voltage impulse is generated at the trigger output (CMOS output with $V_{dd}=5V$).

8. Export of the measurement data

The recorded data are stored in binary form. They can be exported as a (*.txt) or (*.csv) file in different formats (TCDM, hexadecimal, decimal and as physical units. Thereby a selection of single measurement signals is possible.

9. Overview of the functions

The following functions are available:

- Visualizing the SENT-Bus communication
- Recording of the measurement data
- Stop of recording by defined values
- Simulation of the ECU
- Simulation of a sensor
- Export/import of the ECU data
- Export/import of the sensor data
- SENT-Bus parameter editor
- Table list of the measurement data
- Single command editor
- Definition of trigger values
- Analyze and saving trigger events
- Export of trigger events
- Manipulation of the inputs/outputs
- Injection of trigger and reference signals
- Definition of project files and their administration.

10. Connections

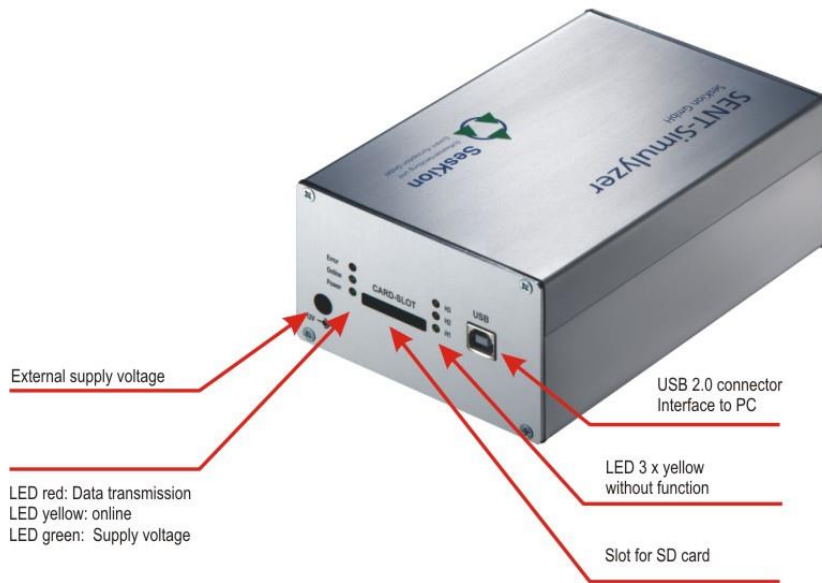

Note:

Supply voltage 12 V via external power supply (1 Ampère)
Ground of the supply voltage is connected with the case!
Ground of the cable signals have to be the same ground!

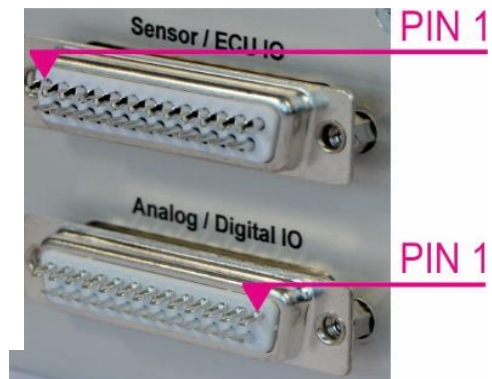

10.1. Interface and digital input/output

Both in common is the reference voltage supply REF193, which affords 3 Volt. In addition, in the measuring and spending analog branch, resistances with an accuracy of 0,1% are used. The used OPs are high impedance OPs. Electric capacitor with leakage currents are not used in the measuring circuit. The AD-Converter has a resolution of 12 Bit. The measure arrangement was developed as simply as possible, to receive no addition of tolerances. The experience shows that the indicated accuracy of < 0.5% is fallen below clearly. A temperature compensation does not take place, because it is assumed that the equipment is used under laboratory conditions.

The analog outputs are used for the analog sensor data. They are logical OP outputs, which are not able to drive great charges. For example, to control a magnet valve an external boost is necessary.

Via the analog outputs the SENT measurement is transmitted. As soon as a new value appears in the SENT, the corresponding output is actualized.

10.2. Block diagram SENT power supply and SENT data

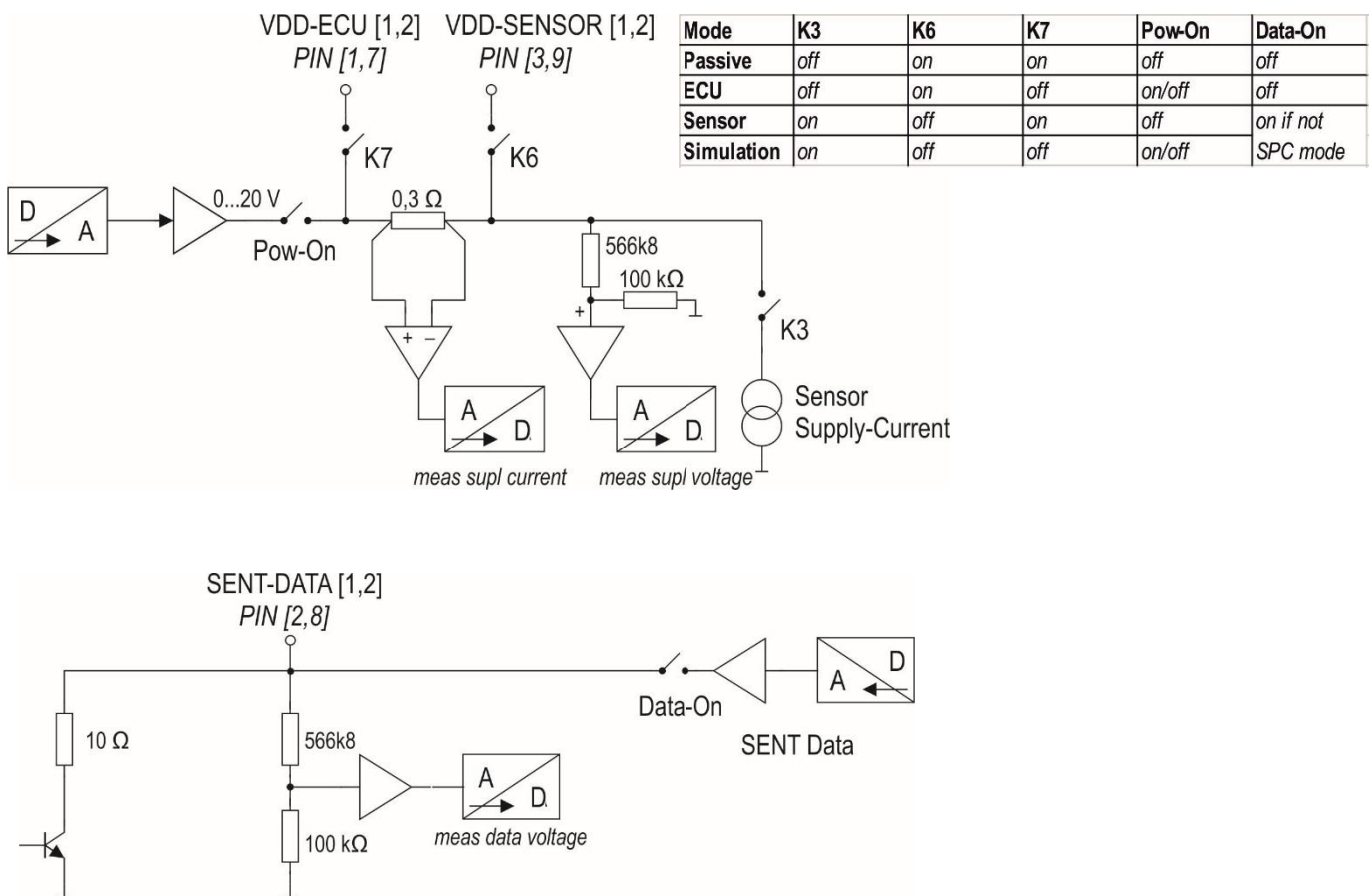

SPC sync-Pulse in ECU mode

SPC data in Sensor mode

10.3. Pin assignment interface 1 and 2

Pin 14 to 17 connected internal -
Wiring of one pin is enough!

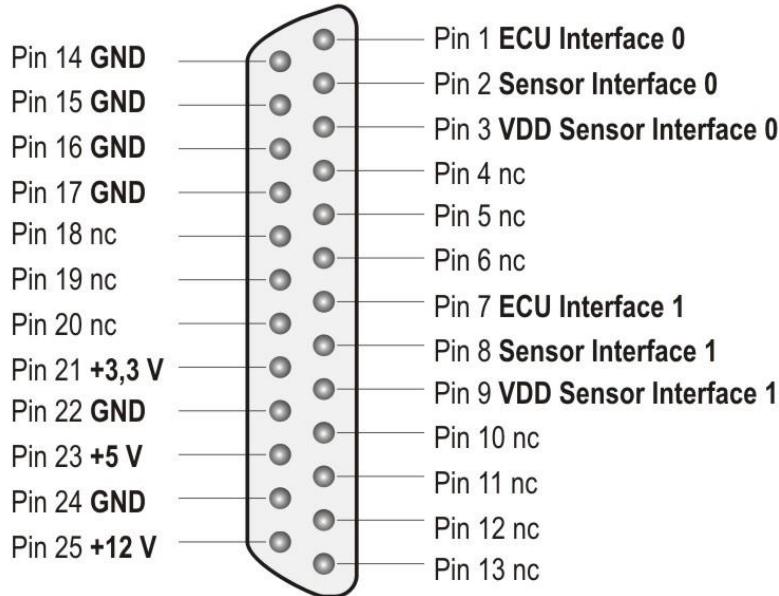

10.4. Pin assignment 25-pol. Digital/Analog I/O - female connector -

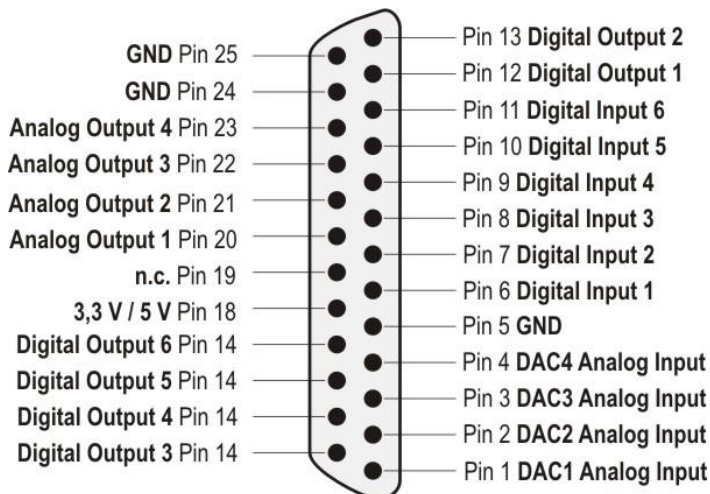

11. Wiring

11.1. Wiring ECU Mode

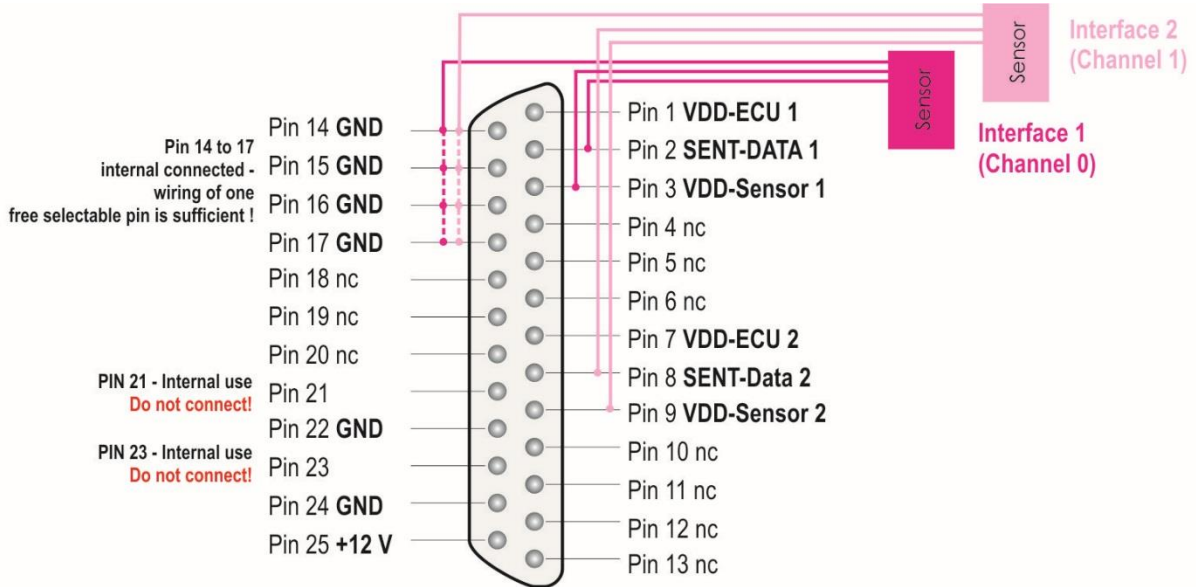

11.2. Wiring Sensor Mode

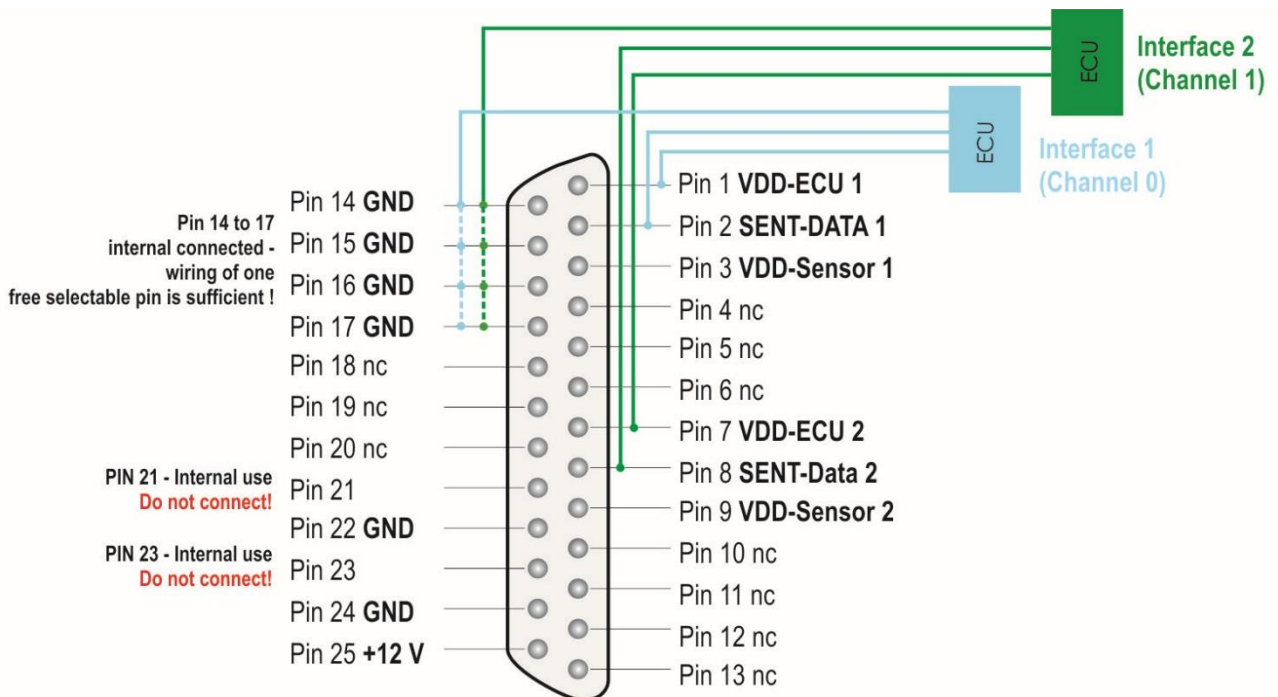

11.3. Wiring Passive Mode

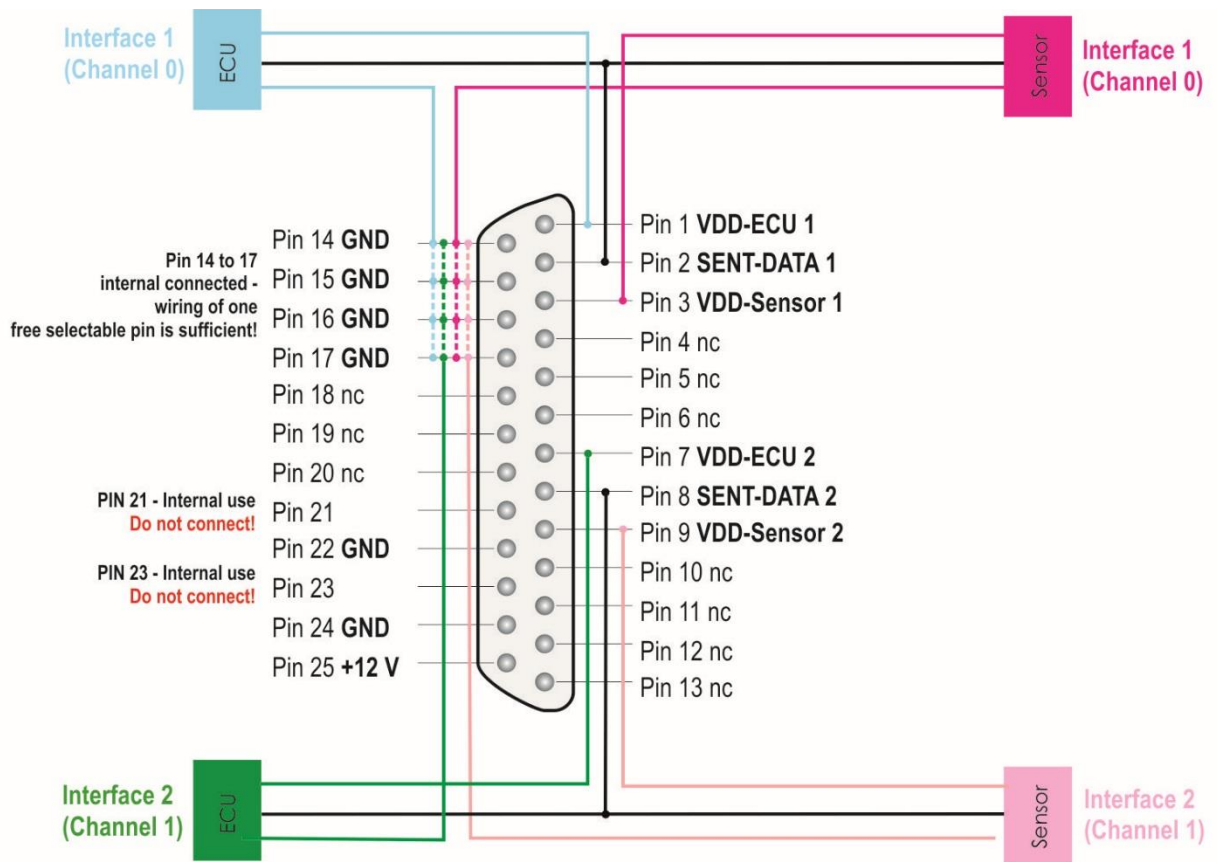

12. Technical data

Dimensions	165 x 105 x 55 mm
Case material	Alu
Wight	1 kg
Operating temperature range	32°F ... 104°F
Acceleration	Max. 3g
Rel. humidity	Max. 85% not condensed

13. Electrical data

Current consumption via USB	Typ. 500 mA
Supply voltage of the external sensors at ECU mode	0 V ... 5,5 V (typ. 3,3V/5V)
Dynam. RAM	128 MB
FPGA Soft μ C Core	32 bit Soft-Core

Note:

The application of an external voltage over 6 V can disturb the *SENT-Simulyzer!*

14. Environmental conditions

Usage sites are electronic engineering labours with corresponding ambient conditions.

15. Software system prerequisites

- Operating system: Windows 7 or 8, XP, 10 (32 or 64 bit)
- Microsoft .Net 2.0 framework. Will be installed automatically.
- Memory: min. 1GB RAM
- Hard disk 100 MB to 4GB free capacity
(limits of the data FIFO)
- Processor: min. 1.5 GHz
- USB 2.0 High-speed interface
- Screen resolution: min. 1024x768 Pixel, opt. 1280x720 Pixel

16. More information and tutorials

Seskion GmbH
Karlsruher Straße 11/1
D-70771 Leinfelden-Echterdingen
Phone: +49 (711) 990 58 14
Fax: +49 (711) 990 58 27
Email: info@seskion.de
URL: <http://www.seskion.de>