

# PSI5-Simulyzer



Hardware version	Up to 2.0
Software version	2.5.2
Technical data sheet version:	1.7
Order number	1.0010
Created:	(1.0) 19.05.2014
	(1.1) 04.08.2014 sample rates
	(1.2) 20.09.2015 Correction supply voltage external sensors
	(1.3) 22.12.2016 Pin assignment pin 1 added
	(1.4) 18.06.2018 Option CAN
	(1.5) 18.11.2018 Pin 1 /operating system update
	(1.6) 19.11.2018 Option board system adapter added
	(1.7) 10.10.2021 Company information edited

### Table of contents:

1. General.....	3
2. Working modes.....	3
2.1 ECU mode .....	3
2.2 Sensor mode.....	3
2.3 Passive mode .....	3
3. PSI5-Bus parameter .....	4
4. Measurement data recording.....	4
4.1 FPGA-Version.....	4
4.2 Sample rates of the Aux inputs .....	4
5. Presentation of the measurement data.....	5
5.1 Graphical presentation .....	5
5.2 Presentation in table form .....	5
6. Stop of the measurement data recording .....	5
7. Trigger of the measurement data - trigger events .....	5
8. Export of the measurement data .....	5
9. Overview of the functions .....	6
10. Connections.....	6
10.1 Option CAN interface .....	7
10.1 Option 12 V Board system adapter .....	7
10.2 Pin assignment 25-pol. digital/analog I/O.....	8
11. Wiring .....	8
11.1 Wiring passive mode.....	8
11.2 Wiring ECU mode .....	9
11.3 Wiring sensor mode .....	9
12. Technical data .....	10
13. Electrical data.....	10
14. Environment conditions .....	10
15. Software system prerequisites .....	10
16. More information and tutorials .....	10

## 1. General

Sensors of automotive technique communicate via PSI5-Bus with the control unit.  
With the *PSI5-Simulyzer* data can be read quickly and easy and is able to react to the situation using simulated data.

The *PSI5-Simulyzer* is connected via USB cable with a Windows-based software.

## 2. Working modes

### 2.1. ECU mode

The *PSI5-Simulyzer* supplies the sensors with voltage. Parallel the data which are sent will be recorded and displayed.

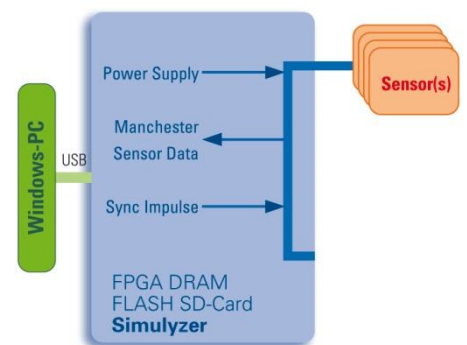

### 2.2. Sensor mode

The *PSI5-Simulyzer* simulates up to 6 sensors by generating according data.  
The data communication between the ECU and the simulated sensors are displayed and recorded.

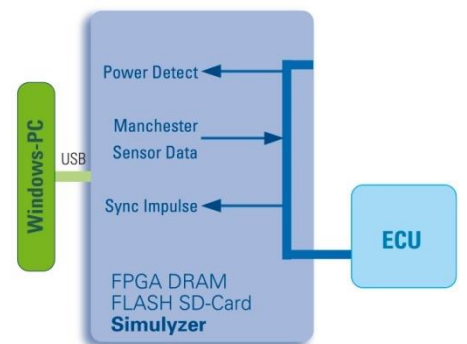

### 2.3. Passive mode:

The data communication between the sensors and the control unit (ECU) will be recorded and visualized.

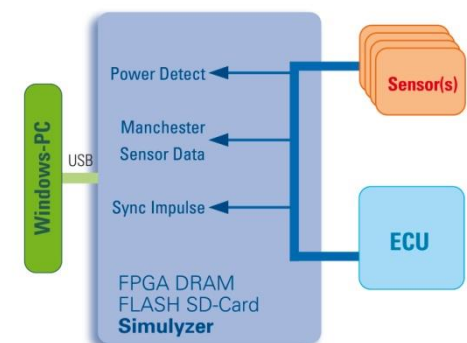

### 3. PSI5-BUS parameter

Data length	13 to 31 bits per data package (parity) 15 to 33 bits per data package (CRC)
Baud rate	Max. 250 kbit/s
Error detection	Parity/CRC
Supply voltage of the external sensors (ECU-Mode)	2,5 V to 20 V
High/Low-voltage level of the digital inputs	2V
High/Low-voltage level of the digital outputs	CMOS outputs with $V_{dd}=2,5\text{ V to }6\text{ V}$

### 4. Measurement recording

The PSI5 data are recorded as a FPGA decoded data in common with a time stamp.

The resolution is 1  $\mu\text{s}$ . The data are stored in a file up to 4 gigabyte. The file is organized as a ring buffer (first in/last out) During this time, the data are shown as permanently changing numbers or characteristics in the presentation window.

#### 4.1. FPGA versions

The respective FPGA version have to be accorded to the respective software version.

History of the FPGA version:

FPGA-Version	Software-Version
0x212	1.15.1
0x212	1.15.2
0x212	1.15.3
0x270	1.15.4
0x270	1.15.5
0x21D	2.3
0x21E	2.4
0x222	2.5.2

#### 4.2 Sample rates of the Aux analog inputs

Samplerrates of the Aux analog inputs depending on the number of used analog inputs:

Sample rates	
1 used input	100 k samples/s
2 used inputs	1. Signal with 50 k samples/s 2. Signal with 50 k samples/s
3 used inputs	1. Signal with 50 k samples/s 2. and 3. Signal with 25 k samples/s
4 used inputs	1. Signal with 50 k samples/s 2 , 3. and 4. Signal with 16,67 k samples/s

## 5. Presentation of the measurement data

### 5.1. Graphical presentation

The data of the ECU as well as the sensors are presented as an analog-signal and as a digital signal with separate free selectable colors over a time axis. Trigger values and CRC resp. Parity error are marked up. The unit of the vertical axis is LSB, but can be changed in other units corresponding to the physical unit. The time section and the zoom of the presentation can be done individual.

### 5.2. Presentation in table form

The measurement data are additionally displayed as a textual table. Thereby each row represents a data frame of the SPI-Master resp. SPI-Slave. At the columns the time stamp, the number of transmitted bits, the hexadecimal value of the transmitted data frame of the ECU and the sensors as well as the extracted measurement data value are displayed. If an parity/CRC error occurs the corresponding line will be highlighted in red.

## 6. Stop of the measurement data recording

After starting the measurement data recording the measurement cycle can be stopped by following variations:

- Manual - by clicking on the stop button of the software
- After a defined time
- After a defined number of cycles.

## 7. Trigger of the measurement data - trigger events

By defining trigger values, specified events (trigger events) can be recorded and saved.

Definition of trigger values:

- Recognize a parity/CRC errors
- Data value levels: go below or beyond of a data value
- External trigger voltage:  
Recognition of a voltage at the trigger input (min. 2 V- max. 5 V)

After trigger a free defined number of data will be recorded. The according trigger events can be stored in defined time sections. By triggering a voltage impulse is generated at the trigger output (CMOS output with  $V_{dd}=5V$ ).

## 8. Export of the measurement data

The recorded data are stored in binary form. They can be exported as a (\*.txt) or (\*.csv) file in different formats (TCDM, hexadecimal, decimal and as physical units. Thereby a selection of single measurement signals is possible.

## 9. Overview of the functions

The following functions are available:

- Visualizing the PSI5-Bus communication
- Recording of the measurement data
- Stop of recording by defined values
- Simulation of the ECU or the sensors
- Export/import of the sensor data
- PSI5-Bus parameter editor
- Table list of the measurement data
- Single command editor
- Measurement data file inspector
- Definition of trigger values
- Analyze and saving trigger events
- Export of trigger events
- Manipulation of the inputs/outputs
- Injection of trigger and reference signals
- Definition of project files and their administration
- Diagnostic mode editor of the sensors.

## 10. Connections

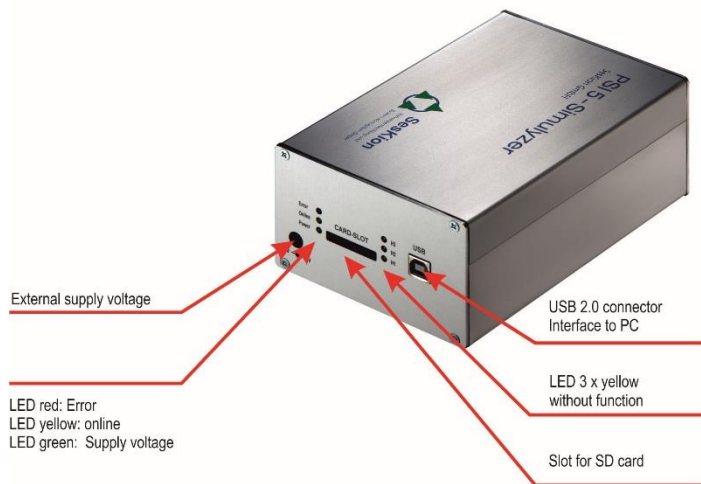

**Note:**

Supply voltage 12 V via external power supply (1 Ampère)

Ground of the supply voltage is connected with the case!

Ground of the cable signals have to be the same ground!

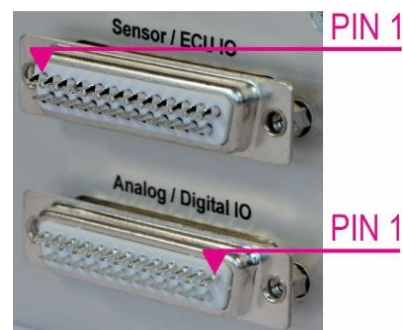

### Interface and digital input/output

Both in common is the reference voltage supply REF193, which affords 3 Volt. In addition, in the measuring and spending analog branch, resistances with an accuracy of 0,1% are used. The used OPs are high impedance OPs. Electric capacitor with leakage currents are not used in the measuring circuit. The AD-Converter has a resolution of 12 Bit.

The measure arrangement was developed as simply as possible, to receive no addition of tolerances. The experience shows that the indicated accuracy of < 0.5% is fallen below clearly. A temperature compensation does not take place, because it is assumed that the equipment is used under laboratory conditions.

The analog outputs are used for the analog sensor data. They are logical OP outputs, which are not able to drive great charges. For example, to control a magnet valve an external boost is necessary.

Via the analog outputs the PSI5 measurement is transmitted. As soon as a new value appears in the PSI5, the corresponding output is actualized.

### 10.1. Option CAN interface

Optionally new devices can be served with an additional CAN-Interface (no retrofit ex post).  
Option 2.1005 "Optional CAN interface - PSI5 Simulyzer built-in order no 1.0010".

Pin	Beschreibung
1	nc
2	CAN low
3	GND
4	nc
5	nc
6	GND
7	CAN high
8	nc
9	nc



**Note:** Terminating resistor between CAN-high and CAN-low is **not** implemented.

### 10.2. Option 12 V Board system adapter

Optionally new devices can be served with a board system version for local use of PSI5 Simulyzer within a car (no retrofit ex post). It serves for protection of high voltage fluctuations to 12 V board system (Option 2.1012 12V Bordnetz Adapter).

Technical data:

Minimal permanent supply voltage	8 V
Current consumption during minimal permanent supply voltage	1000 mA
Maximal permanent supply voltage	17 V
Current consumption during maximal permanent supply voltage	450 mA
maximal jump start supply voltage (60 s)	26 V
transiente undervoltage (20 ms)	6 V
transiente overvoltage (400 ms)	18 V

2-pole plug-in feeder clamp (max. 1.5 mm<sup>2</sup>) for board system supply

LED  
off= no voltage  
green= voltage supply  
rot = fuse error/exchange

Fuse2 A delay exchangeable

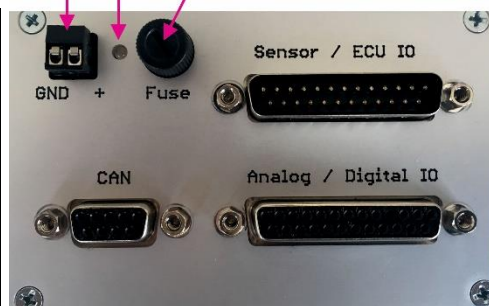

### 10.3. Pin assingment 25 pol. digital/analog I/O female connector

**25-pole SUB-D Socket Digital / Analog IO**

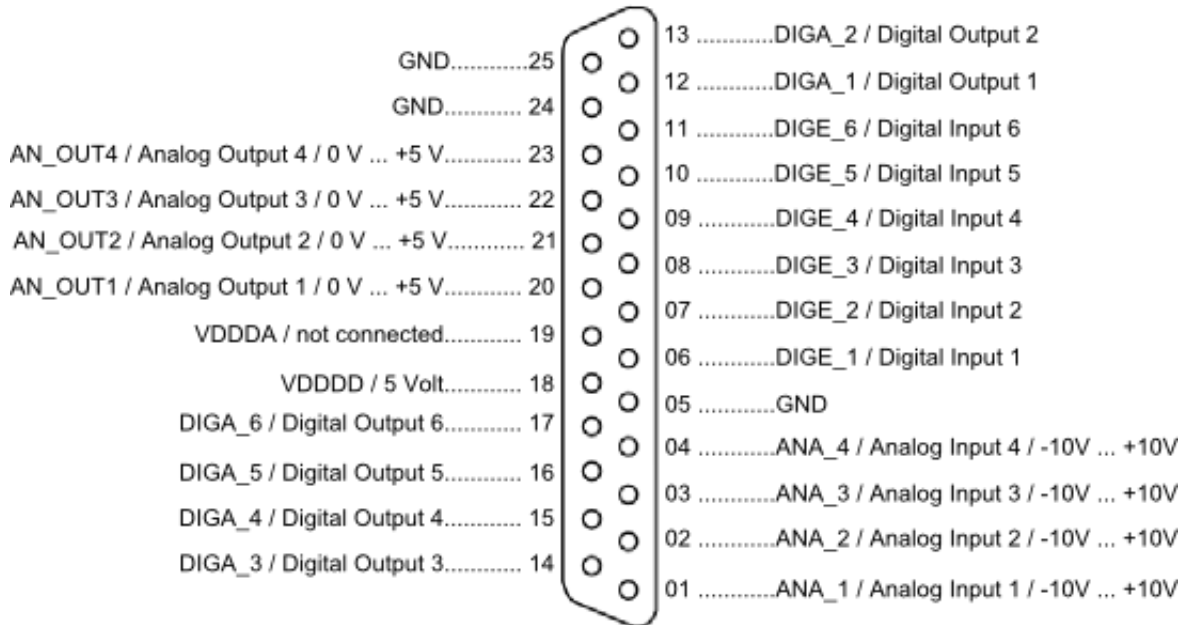

## 11. Wiring

### 11.1. Wiring Passive Mode

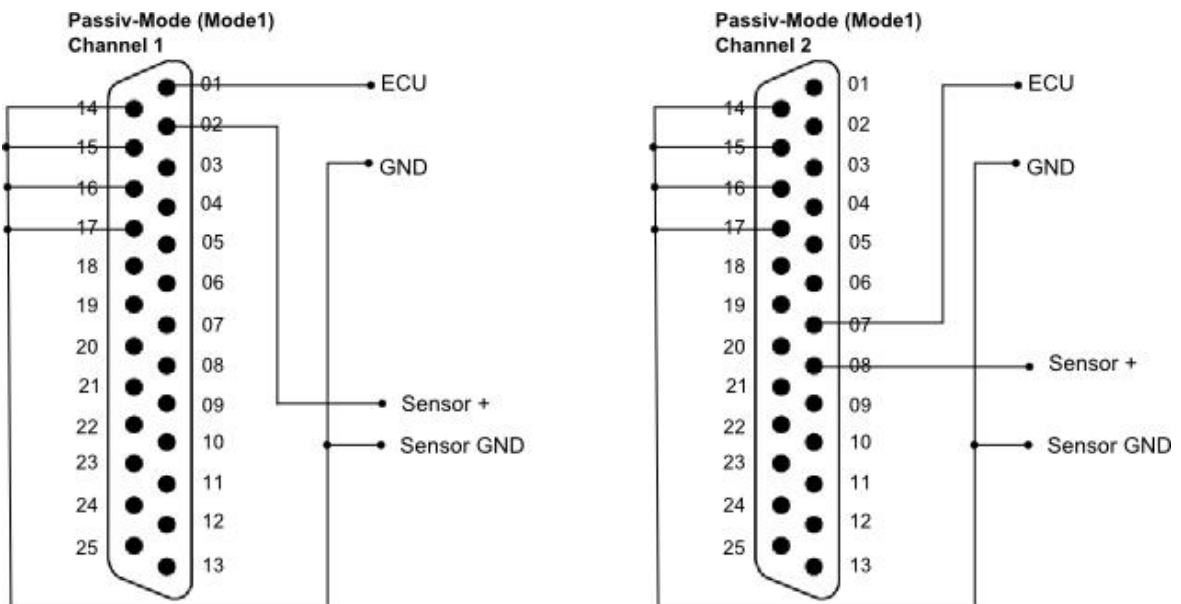



### 11.2. Wiring ECU Mode

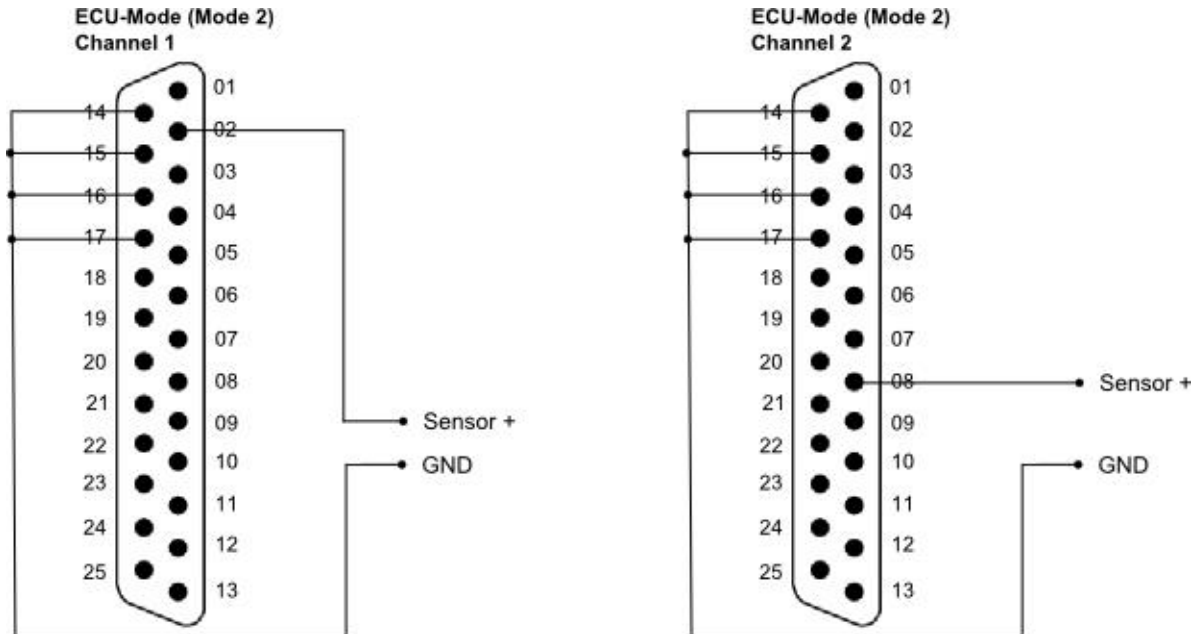

### 11.3. Wiring Sensor Mode

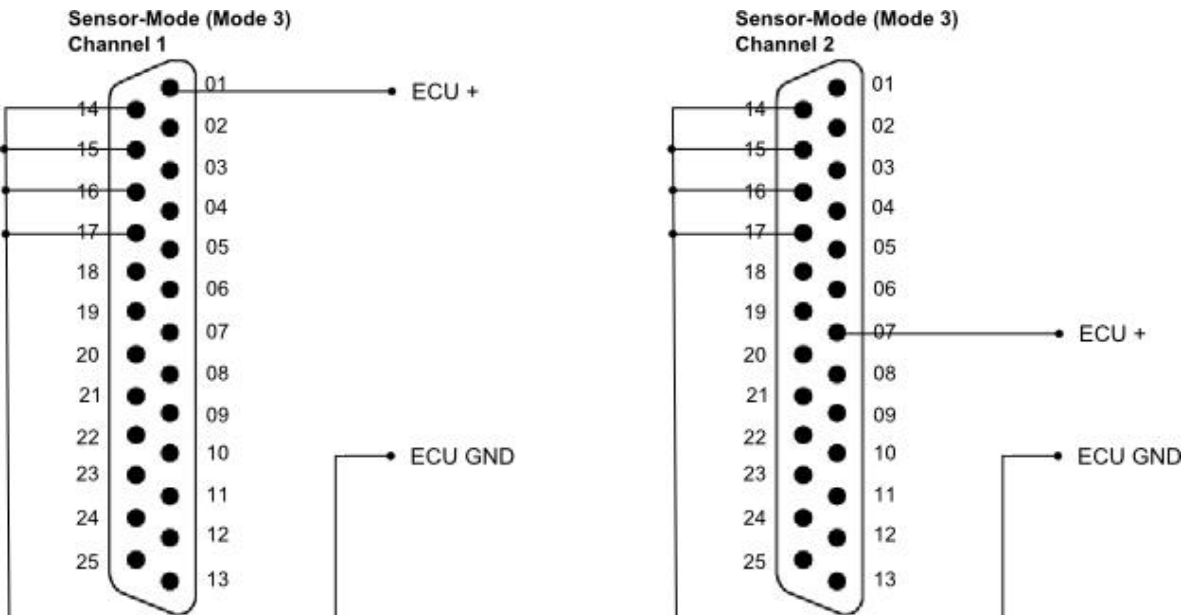

## 12. Technical data

Dimensions	165 x 105 x 65 mm
Case material	Alu
Wight	1,1 kg
Operating temperature range	0°C ... 40°C
Acceleration	Max. 3g
Rel. humidity	Max. 85% not condensed

## 13. Electrical data

Current consumption via USB	Typ. 500 mA
Supply voltage of the external sensors at the ECU mode	0 V ... 20 V
Dynam. RAM	128 MB
FPGA Soft $\mu$ C Core	32 bit Soft-Core

### Note:

The application of an external voltage over 6 V can disturb the *PSI5-Simulyzer!*

## 14. Environmental conditions

Usage sites are electronic engineering labours with corresponding ambient conditions.

## 15. Software system prerequisites

- Operating system: Windows 7 or 8, XP,10 (32 or 64 bit)
- Microsoft .Net 2.0 framework. Will be installed automatically.
- Memory: min. 1GB RAM
- Hard disk 100 MB to 4GB free capacity (limits of the data FIFO)
- Processor: min.1.5 GHz
- USB 2.0 High-speed interface
- Screen resolution: min.1024x768 Pixel, opt. 1280x720 Pixel

## 16. More information and tutorials

Seskion GmbH  
Karlsruher Straße 11/1  
D-70771 Leinfelden-Echterdingen  
Phone: +49 (711) 990 58 14  
Fax: +49 (711) 990 58 27  
Email: [info@seskion.de](mailto:info@seskion.de)  
URL: <http://www.seskion.de>