

Simulyzer-RT PWR-ANA-1 Card

Power-Analog Card

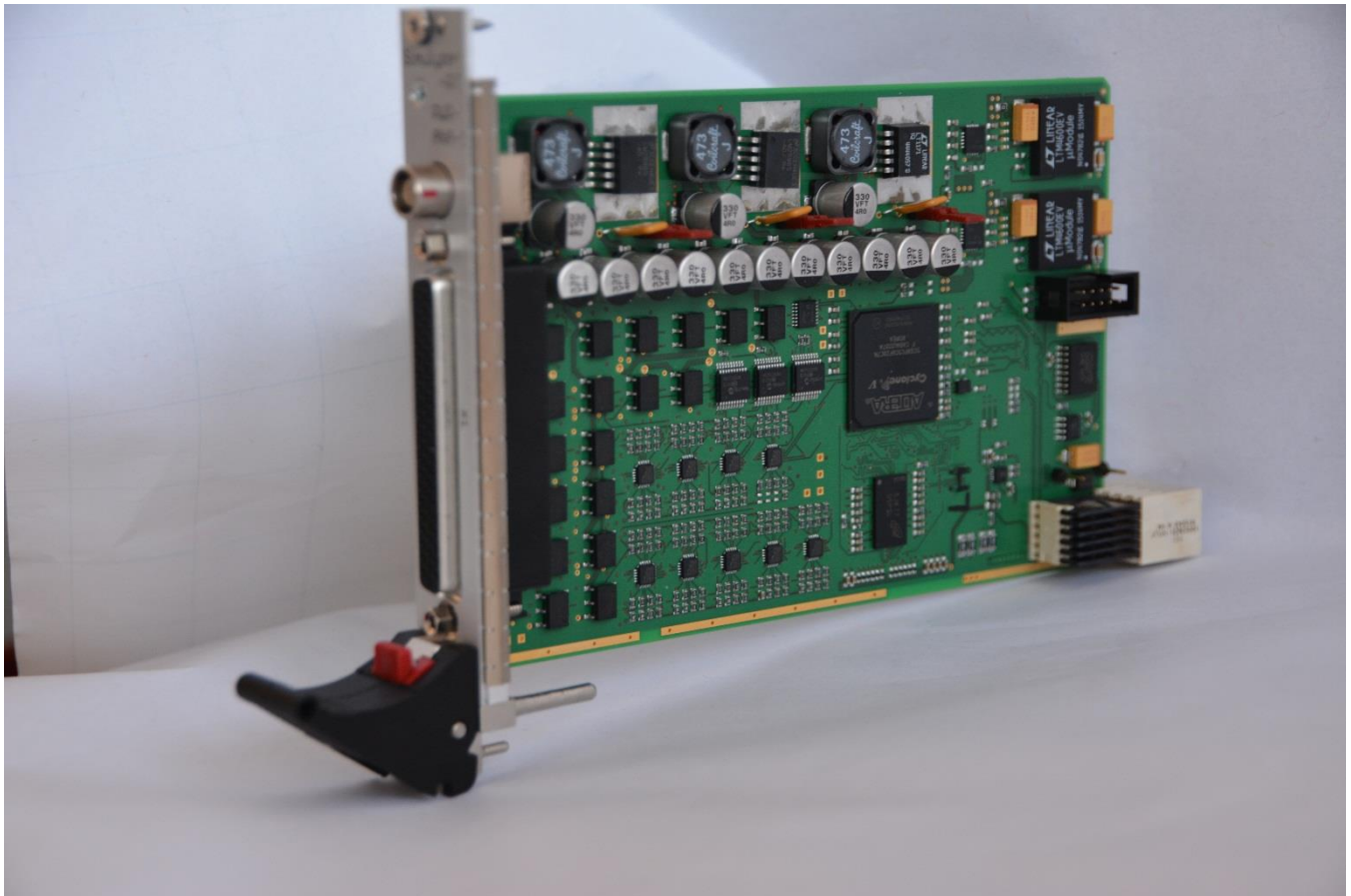

Hardware version	1.1
Documentations version:	1.2
Created:	Jan 2018
	1.1 April 2016 Note HF sealing spring 1.2 I_{bias} and Bandwidth
Order no:	1.1017

Safety instructions

To avoid damages to persons and devices the following safety instructions have to be noticed!

- Only qualified personnel are allowed to handle this device!
- Before any handling within the device the current supply has to be switched off!
- During operation the device have to be positioned, that enough air condition is supplied and no small parts can get into the ventilation slots.
- In case of any trouble the system has to be switched de-energized!
- The declared environmental conditions and max. voltage ranges have to be observed!
- To warranty the device remove all dust and dirt in periodically intervals.
- Make sure that the ventilation slots are unobstructed!

Intended Use:

The Simulyzer-RT PWR-ANA-1 card is engineered to supply voltage for a Simulyzer-RT system with higher power need. The functionality of the PWR-ANA-1 card is to provide voltage and to measure sensor currents.

- The device is only permitted to use for the intended use.
Any other use results the deletion of the guarantee!

For questions and repair cases contact SesKion GmbH

Tel.: +49 (0)711/990 58 14

Fax: +49 (0)711/990 58 27

Email: info@seskion.de

Internet: www.seskion.de

Table of contents

Table of contents	3
1. Technical data	4
2. Measurement accuracy	5
2.1. Time base	5
2.2. Measurement of the V_Aux [1,2]_[1...8] voltages (100k samples/s)	5
2.3. Measurement of the V_Aux [3]_[1...8] voltages (100k samples/s)	5
2.4. Measurement of the supply voltage (10k samples/s)	5
2.5. Measurement of supply current (10k samples/s)	5
2.6. Generation of voltage	5
3. Block diagram	6
4. Connectors:.....	7
5. Handling card/chassis	7
6. Connection diagram	8

1. Technical data

	Symbol	Typ	Min	Max	Note
Supply voltage	U_{Supp}	12 V	11.4 V	12.6 V	
Current consumption	I_{Supp}	350 mA	-	-	Without sensoren
Supply and measurement of 2 supply voltages for 8 sensors	Possible BUS systems: SPI-,LIN-,SENT-,CAN or I ² C-sensors				
Operating temperature:	32° F ... 104°F				
Rel. Humidity	Max. 85% not condensed				
Weight	170 g				
Dimensions	Euroformat 4 U				
Standard specifications	EN 61326-1, EN 61000-6-2, EN 61000-6-3				

Characteristics and FPGA		
Supply voltage	2 V ... 20 V adjustable, 1 A External backward measurement of 8x2 supply voltages + 1xGND	14 bit resolution short-circuit proofed and thermic protected
Supply current	0 mA ... 150 mA measurable	14 bit resolution Shunt of the supply current measurement: 0,1 Ohm
PCI Express	Protocol of PCIe 2.1	Max. speed 2,5 GBit/s
Sample rate	Measurement V_Aux [1...3]_[1...8]	Max. 100k samples (10µs sample distance)
	All other measurements	Max. 10k samples (100µs sample distance)
Input-resistance	V_Aux [1...3]_[1...8]	100 kOhm
Input voltage range	V_Aux [1,2]_[1...8]	0..5V
Input voltage range	V_Aux [3]_[1...8]	0..25V
Input bandwidth (-3dB)	V_Aux [1...3]_[1...8]	25kHz
500MByte DDR3 RAM for NIOS µC, instantiable 32-Bit NIOS µC in FPGA		
ALTERA FPGA Cyclone V to realize protocols		

2. Measurement accuracy

2.1. Time base

Test conditions: Environmental temperature 20°C bis 26°C (68° to 79°F)						
Num	Evaluation	Symbol	Typ	Max	Unit	Note
1	Accuracy time base	$\Delta f/f$	±30	±50	ppm	-
2	Aging time base	$\Delta f/f_A$	±5		ppm/year	-
3	Temperature drift of the time base	$\Delta f/f_T$	±0.3	±0.7	ppm/K	-

2.2. Measurement of the V_Aux [1,2] [1...8] voltages (100k samples/s)

Test conditions: Environmental temperature 20°C bis 26°C (68° to 79°F)						
Num	Evaluation	Symbol	Typ	Max	Unit	Note
	Input Bias Current	I_B	0.4	0.7	µA	
13	Accuracy of the measured voltage	U_{mea}	±0.075	±0.1	% of scfin 5 V	Range 0.1V ...4.9V
14	Aging of the measured voltage	U_{A-meas}		±0.025	%/year	Range 0.1V ...4.9V
15	Resolution of the measured voltage		14		Bit	0...16383
			0.305175781		mV/LSB	

2.3. Measurement of the V_Aux [3] [1...8] voltages (100k samples/s)

Test conditions: Environmental temperature 20°C bis 26°C (68° to 79°F)						
Num	Evaluation	Symbol	Typ	Max	Unit	Note
	Input Bias Current	I_B	0.16	0.29	µA	
16	Accuracy of the measured voltage	U_{mea}	±0.075	±0.1	% of scfin 25 V	Range 0.5V ...24.5V
17	Aging of the measured voltage	U_{A-meas}		±0.025	%/year	Range 0.5V ...24.5V
18	Resolution of the measured voltage		14		Bit	0...16383
			1.5258789		mV/LSB	

2.4. Measurement of the supply voltage (10k samples/s)

Test conditions: Environmental temperature 20°C bis 26°C (68° to 79°F)						
Num	Evaluation	Symbol	Typ	Max	Unit	Note
4	Accuracy of the measured voltage	U_{mea}	±0.075	±0.1	% of scfin 20 V	Range 1V ...18V
5	Aging of the measured voltage	U_{A-meas}		±0.025	%/year	Range 1V ...18V
6	Resolution of the measured voltage		14		Bit	0...16383
			1.22		mV/LSB	

2.5. Measurement of supply current (10k samples/s)

Test conditions: Environmental temperature 20°C bis 26°C (68° to 79°F)						
Num	Evaluation	Symbol	Typ	Max	Unit	Note
7	Accuracy of the measured current	I_{mea}	±0.1	±0.15	% of scfin 180mA	Range 2mA ... 100mA
8	Aging of the measured current	I_{A-meas}		±0.05	% of scfin / year	Range 2mA ... 100mA
9	Resolution of the measured current		14		Bit	0...16383
			9.15527		µA/LSB	

2.6. Generation of voltage

Test conditions: Environmental temperature 20°C bis 26°C (68° to 79°F)						
Num	Evaluation	Symbol	Typ	Max	Unit	Note
10	Accuracy of the generated voltage	U_{mea}	±0.3	±0.4	% of scfin 20V	Range 2V...18V
11	Aging of the generated voltage	U_{A-meas}		±0.1	% of scfin .20V / Jahr	Range 2V...18V
12	Resolution of the generated voltage		14		Bit	0...16383
			0.30517578		mV/LSB	

3. Block diagram

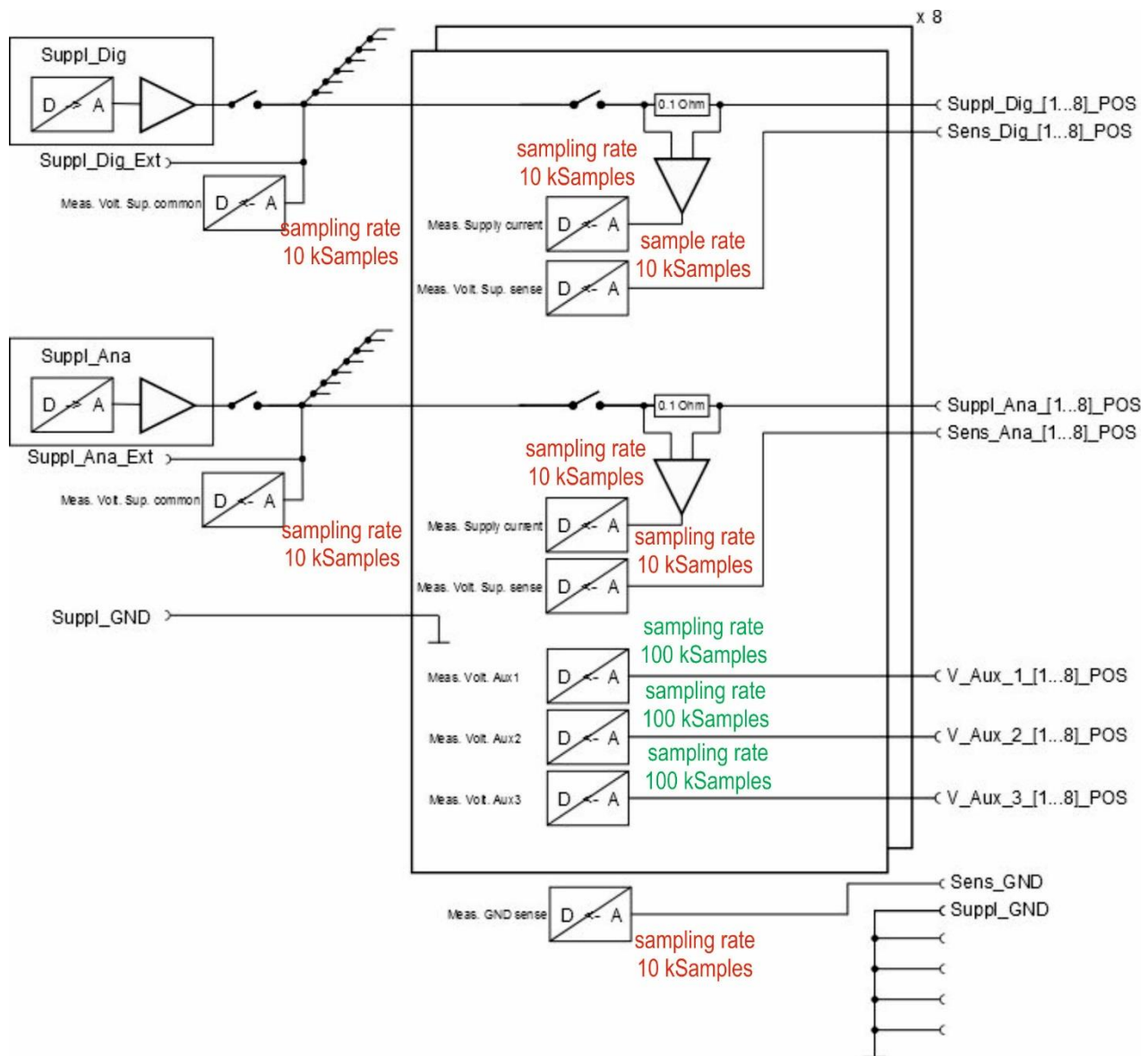

The PWR-ANA-1 card generates two turn-off voltages (`Suppl_Dig_n` und `Suppl_Ana_n`), which each supplies 2 V to 20 V/1 A. This voltages provide the 8 interfaces and can be switched on/off individually.

Additional the voltages can be switched off to enable the injection of external supply voltages.

For each sensor there are 3 additional analog inputs for measurement of the analog outputs of the sensors.

The backward measurement of the GND potential of the sensor intake card is done by a further analog input, common for all sensors.

Recording of the measurement values is done with a time stamp, clocked synchronously with the common 100 MHz clock of the bus. The synchronization of the time stamp start is done parallel to all periphery cards.

4. Connectors:

- Connector to the bus: 1 PCIe Lane to CPU-1
Current supply I2C
parallel to all cards for synchronization
- Connectors front: HD D-Sub 62 Pin female connector with periphery
7 Pin each sensor interface:
Suppl_n_out, Suppl_n_in, 3 x Aux_in.n, GND-in, 5x1Pin GND (common)

4-pol. LEMO-female connector to inject external power supply



5. Handling card/chassis

Pay attention that the ejection lever of the plug-in card is arrested correctly. Only the correct position guarantees a justly connection of the bus system and the power supply!

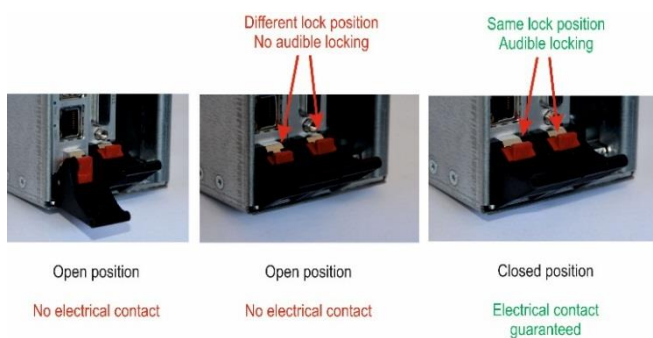

Note

The forcible insertion of the card with displaced HF-sealing spring will damage them. As a result of that HF energy emission will be increased!

Only with intact HF-sealing spring we guarantee that the whole system conforms to the EMC guidelines.

HF-sealing spring

6. Connection diagram

62 pol. Sub-D-female connector X1

Pin	Name	Interface	Comment	Pin	Name	Interface	Comment
X1-2	Suppl_Dig_out.1	1	Supply voltage output 1 (dig)	X1-14	Suppl_Dig_out.6	6	Supply voltage output 1 (dig)
X1-3	Suppl_Ana_out.1		Supply voltage output 1 (ana)	X1-15	Suppl_Ana_out.6		Supply voltage output 1 (ana)
X1-23	Sens_Dig_in.1		Supply voltage sens Input 1 (dig)	X1-35	Sens_Dig_in.6		Supply voltage sens Input 1 (dig)
X1-24	Sens_Ana_in.1		Supply voltage sens Input 1(ana)	X1-36	Sens_Ana_in.6		Supply voltage sens Input 1(ana)
X1-22	V_Aux1_in.1		Aux analog input 1_1	X1-55	V_Aux1_in.6		Aux analog input 1_1
X1-43	V_Aux2_in.1		Aux analog input 2_1	X1-56	V_Aux2_in.6		Aux analog input 2_1
X1-44	V_Aux3_in.1		Aux analog input 3_1	X1-57	V_Aux3_in.6		Aux analog input 3_1
X1-4	Suppl_Dig_out.2	2	Supply voltage output 2 (dig)	X1-17	Suppl_Dig_out.7	7	
X1-5	Suppl_Ana_out.2		Supply voltage output 2 (ana)	X1-18	Suppl_Ana_out.7		
X1-25	Sens_Dig_in.2		Supply voltage sens Input 2 (dig)	X1-38	Sens_Dig_in.7		
X1-26	Sens_Ana_in.2		Supply voltage sens Input 2(ana)	X1-39	Sens_Ana_in.7		
X1-45	V_Aux1_in.2		Aux analog input 1_2	X1-37	V_Aux1_in.7		
X1-46	V_Aux2_in.2		Aux analog input 2_2	X1-58	V_Aux2_in.7		
X1-47	V_Aux3_in.2		Aux analog input 3_2	X1-59	V_Aux3_in.7		
X1-7	Suppl_Dig_out.3	3	Supply voltage output 3 (dig)	X1-19	Suppl_Dig_out.8	8	
X1-8	Suppl_Ana_out.3		Supply voltage output 3 (ana)	X1-20	Suppl_Ana_out.8		
X1-28	Sens_Dig_in.3		Supply voltage sens Input 3 (dig)	X1-40	Sens_Dig_in.8		
X1-29	Sens_Ana_in.3		Supply voltage sens Input 3(ana)	X1-41	Sens_Ana_in.8		
X1-27	V_Aux1_in.3		Aux analog input 1_3	X1-60	V_Aux1_in.8		
X1-48	V_Aux2_in.3		Aux analog input 2_3	X1-61	V_Aux2_in.8		
X1-49	V_Aux3_in.3		Aux analog input 3_3	X1-62	V_Aux3_in.8		
X1-9	Suppl_Dig_out.4	4	Supply voltage output 4 (dig)	X1-1	GND	8	Common GND
X1-10	Suppl_Ana_out.4		Supply voltage output 4 (ana)	X1-6	GND		
X1-30	Sens_Dig_in.4		Supply voltage sens Input 4 (dig)	X1-11	GND		
X1-31	Sens_Ana_in.4		Supply voltage sens Input 4 (ana)	X1-16	GND		
X1-50	V_Aux1_in.4		Aux analog input 1_4	X1-21	GND		
X1-51	V_Aux2_in.4		Aux analog input 2_4	X1-42	Sens_GND_in		GND sens input
X1-52	V_Aux3_in.4		Aux analog input 3_4				
X1-12	Suppl_Dig_out.5	5	Supply voltage output 5 (dig)				
X1-13	Suppl_Ana_out.5		Supply voltage output 5 (ana)				
X1-33	Sens_Dig_in.5		Supply voltage sens Input 5 (dig)				
X1-34	Sens_Ana_in.5		Supply voltage sens Input 5 (ana)				
X1-32	V_Aux1_in.5		Aux analog input 1_5				
X1-53	V_Aux2_in.5		Aux analog input 2_5				
X1-54	V_Aux3_in.5		Aux analog input 3_5				

X1-1	GND
X1-2	Suppl_Dig_out.1
X1-3	Suppl_Ana_out.1
X1-4	Suppl_Dig_out.2
X1-5	Suppl_Ana_out.2
X1-6	GND
X1-7	Suppl_Dig_out.3
X1-8	Suppl_Ana_out.3
X1-9	Suppl_Dig_out.4
X1-10	Suppl_Ana_out.4
X1-11	GND
X1-12	Suppl_Dig_out.5
X1-13	Suppl_Ana_out.5
X1-14	Suppl_Dig_out.6
X1-15	Suppl_Ana_out.6
X1-16	GND
X1-17	Suppl_Dig_out.7
X1-18	Suppl_Ana_out.7
X1-19	Suppl_Dig_out.8
X1-20	Suppl_Ana_out.8
X1-21	GND
X1-22	V_Aux1_in.1
X1-23	Sens_Dig_in.1
X1-24	Sens_Ana_in.1
X1-25	Sens_Dig_in.2
X1-26	Sens_Ana_in.2
X1-27	V_Aux1_in.3
X1-28	Sens_Dig_in.3
X1-29	Sens_Ana_in.3
X1-30	Sens_Dig_in.4
X1-31	Sens_Ana_in.4
X1-32	V_Aux1_in.5
X1-33	Sens_Dig_in.5
X1-34	Sens_Ana_in.5
X1-35	Sens_Dig_in.6
X1-36	Sens_Ana_in.6
X1-37	V_Aux1_in.7
X1-38	Sens_Dig_in.7
X1-39	Sens_Ana_in.7
X1-40	Sens_Dig_in.8
X1-41	Sens_Ana_in.8
X1-42	Sens_GND_in
X1-43	V_Aux2_in.1
X1-44	V_Aux3_in.1
X1-45	V_Aux1_in.2
X1-46	V_Aux2_in.2
X1-47	V_Aux3_in.2
X1-48	V_Aux2_in.3
X1-49	V_Aux3_in.3
X1-50	V_Aux1_in.4
X1-51	V_Aux2_in.4
X1-52	V_Aux3_in.4
X1-53	V_Aux2_in.5
X1-54	V_Aux3_in.5
X1-55	V_Aux1_in.6
X1-56	V_Aux2_in.6
X1-57	V_Aux3_in.6
X1-58	V_Aux2_in.7
X1-59	V_Aux3_in.7
X1-60	V_Aux1_in.8
X1-61	V_Aux2_in.8
X1-62	V_Aux3_in.8
X1_case	GND

Connection Lemo

1	GND
2	GND
3	U_Dig_Lemo
4	U_Ana_Lemo

Equipment Lemo-female connector:
4-wire cable length 2 m with mating plug
Order no.: 1.1016